

Money Creation and Control from Islamic Perspective

Prof. Dr. Zubair Hasan^{*}

Abstract

This paper deals with familiar facts in monetary economics from an unfamiliar angle. It argues that it is not factual to regard the legal tender money and bank credit as of different genus: they work in tandem to the same ends in an economy, conventional or Islamic. Also, it does not matter what serves as money – solid gold or flimsy paper – for keeping its value stable; only the blind would argue that staff is indispensable for walking. Money is just an instrument: it was never nor can ever be classified into Islamic and non-Islamic. What it does – good or bad – depends on how we use it. Money does not generate crises; its mismanagement does. It follows that the refuge the world is searching today from recurring financial crises does not lie in money substance: history testifies that national economies could not remain turmoil-free during the centuries of the yellow metal sway over the monetary scene. The paper concludes that it is the human factor that has been the source of good or evil for mankind including money matters. And the quality of human factor true religion can alone improve: morality without faith is rudderless.

Key words: Monetary policies; Gold standard, managed currency; Islamic banking; Central banks

1. Introduction

At the dawn of societal living economies were run by a system known as barter: A person exchanged whatever good or service he had with the goods or services others possessed. Barter required *double coincidence of wants* – B should not only have what A wanted but must also be in need of what A could offer in exchange. This was restrictive of transactions that could be made, consumed more time and curtailed specialization. The frustrations barter imposed on human ambitions led people to create money. We can define money by what it does i.e. by its *functions* or by identifying the *substance* which performed those functions. The temporal uniformity of the notion lies in the functional approach because what substance performed those functions over time and space is a welter of things approaching infinity. But herein lays the romance of money. From

^{*} Department of Economics & Governance
INCEIF: Global University of Islamic Finance; Malaysia

hides and skins via cowrie shells, salt, spices and precious metals to promise to pay working as money has been a fascinating journey of human ingenuity.

The functional approach to the definition of money sees its significance in serving as a medium of exchange, as a measure and a store of value and as a unit of account. In essence, these functions help tear apart the two sides of the barter coin – sale and purchase. You can sell what you have for money, keep that money with you and buy at will what you want and when. The eventual exchange involves real goods and services at both ends; money works merely as a go-between. If paper or plastic can perform the functions efficiently why use much more valuable things to serve as money? If roads could be built in the air will that not release land for growing more food? Money derives its significance from its *general acceptability* and that acceptability stems from its value remaining stable, not from the value of what it is made. We do not print cinema tickets on chocolate so that people could eat them in case they miss the movie.

Why are then suggestions today for a return to gold as the fulcrum for restructuring the international monetary system?¹ To me, psychology, haplessness, loss of direction and presumably some national interests are among the major factors. The search for an answer drags us back to the history of the money's evolution. This we do in the following Section 2. In section 3 we shall argue that it is not the systemic failure but the demise of human integrity that has pushed the world to the brinks of disaster. In Section 4 we summarize the argument and present a few policy prescriptions for consideration.

2. Evolution of Money

2.1 A social convention

Money was not invented: it evolved as a social convention and took various forms over time and space. This lent precedence to money substance over its functions in discussions on the subject. The importance of what works as money was reinforced as in the process of measuring the value (prices) of other goods and services money assumed a value for

¹ The suggestion that surprised many came from a person of no less stature than the World Bank governor Bob Zoellick (December 2010). Interestingly, it gave a boost to the clamor for a return to Gold Dinars and several articles on the subject made their appearance on the heels of Bob's statement including Karim (2010), KFH Research (2010) and Zein (2011)

itself that fluctuated inversely with variations in the general price levels over time and space. In that money was a different sort of measure compared to others that we use in our daily lives. Money made of or linked to something valuable in use, like gold or silver, made its value fluctuate inversely with those of other goods and services. The stability in the internal value of money thus requires the controlling of fluctuations in the domestic price level. Also, what worked as money in various countries is not mostly identical. This gave rise to the issues relating to the determination of the values of different moneys in terms of each other or foreign exchange rates for promoting inter-nation trade. The rising tide of international trade with the passage of time demanded something tangible that could help local monies enable their mutual convertibility. The need added to the significance of substance for the role money played in an economy.

Bronze and copper were the first to get converted into coins but gold and silver did not take much to replace them. Gold silver coins were made in Lydian – modern Turkey - as early as around 560 BC and could well be regarded the earliest forms of metallic coins. However, these coins were too soft to withstand the wear and tear in circulation or resist corrupt clippings resulting in their weight falling below the initial measure. Gold and silver had to be mixed with alloy to make coins adequately hard. This demanded standardization of the alloy proportion in the coins to ensure their authenticity and uniformity in terms of their precious metal content. The work was done by informal private agencies for most part of the 2500 years of sway the yellow metal had over the monetary matters across the world. Touchstones were used to verify the purity of coins in terms of their fineness. the convention continued even beyond the publication of Smith's *Wealth of Nations*, 1776. Indeed, the author was much impressed by the spontaneous evolution of such benevolent social institutions as money, division of labor and capital accumulation that played such a vital role in promoting growth in the *wealth of nations*.² Note that gold standard in England was established by an Act of Parliament only in 1860 and in the USA much later in 1900.

² See Gide & Rist (1953) for an excellent analysis of this influence under a sub-title: *The naturalism and optimism of Smith* pp. 85-109. One would not presumably come across such detailed and graphic description of the subject in other books on the History of Economic Thought.

2.2 State entry

In the private manufacture of coins, the standardization process required that gold was pre-alloyed and coins were weighted before they went into circulation. As long as people knew the manufacturer and had trust in him no touchstones were needed. At the time when Islam made its appearance on the scene, the gold coins in circulation were made in Rome and carried the stamping of pagan idols. The fact that the Prophet (Peace be upon him) allowed their remaining in circulation, testifies by implication that the faith did not divide money into Islamic and non-Islamic. However, to continue with the thread, the governments soon started stamping the coins with an emblem to strengthen the process of standardization. The emblem was a guarantee for the weight of the coin, its degree of purity and its value. The facility gave people the satisfaction of carrying value within their money, but it could not prevent the loss of precious metal in the circulation process and more than that through clipping of coins for recycling. Carrying money in pockets and over space involved both cost and risk. Governments of all shades soon discovered that coins derived their value essentially from the emblem; they often debased the coins to lower their precious metal content. To that extent coins became no better than notes printed on metal. This led Gresham to postulate during the Victorian era that bad (debased) money drives good (full-bodied) money out of circulation.³ Finally, the side by side circulation of coins made of gold, silver and copper in many places, especially in Europe, led merchants to place premium on gold and distort the relative price of metals.

2.2.1 From metals to paper

To overcome the above mentioned difficulties of commodity money – the coins – banks began to issue paper receipts to depositors stating that the receipt was redeemable for the precious metals stored with them. Soon the receipts started circulating as money because everyone started taking them as good as gold. They were representative of the yellow metal. The suggestion for enforcing a 100% reserve requirement today, especially in

³ Could that be the reason for the Qur'an to condemn the hoarding of gold and silver (9: 34-35)? Some claim gold and silver are Islamic money and their hoarding will reduce the quantity of money in circulation to the disadvantage of the economy; so the condemnation of hoarding these metals. I have a different interpretation. The reference in the two verses is explicitly to the stock of metals for which Zakat has not been paid. Even after Zakah has been paid it may not be desirable to retain money just for the sake of pleasure of seeing and touching it at will but it may not be punishable the way the verses state.

Islamic economics, derives its inspiration from the policy of that era. But much water has since turned in the ocean around the world.

It soon became apparent that to spend money and toil to dig the glittering metal out from the bowels of earth only to lock it back into the dark vaults of banks was an avoidable folly. To the relief of our pretty ladies, representative money proved just a small step to usher in the practice of banking based on fractional reserve. Banks were soon printing receipts above and beyond the amount of yellow metal deposited with them. It benefited traders and enriched the bankers. Paper notes had appeared in China as early as the year 806 AD and dominated the scene until the middle of fifteenth century. China stopped using paper notes in 1455 because their overproduction led to high inflation. But the fractional reserve system being an easy and effortless way for self-enrichment, the banks could not curb the temptation to over issue the notes. Intermittent bouts of inflation became rampant across the world. If the linkage of money to gold at its zenith could not stop the emergence of the malady; on what basis can the advocates for its revival can convince one that the resuscitation of gold can ensure it today? Inflation could not, as it cannot, sustain itself for long because it carries *within* its fold the weapons for its own demise. Sooner or later, it must turn its tail upward to nosedive. The slump that the burst of the bubble generates is found to be sticky and more damaging. We shall return to the issue in some detail later. Presently, we turn to the two interesting developments in monetary history that the non-sustainability of inflation triggered.

The first was the emergence of the state as a monopolist for the conversion of gold into coins and of coins into gold at the official mint. Initially, this service to people was rendered free of cost but later on a small fraction of gold (or silver) brought to the mint for coinage was used to be taken out to cover manufacturing costs. The deduction was known as the *seignorage* – the right of the king/lord over the possessions of the commoners. Thus, free coinage did not mean free of cost. It meant that people were free to bring for conversion into coins at the mint only the indicated precious metals – gold or silver.⁴ The main reason for

⁴ Coins were divided into two types: Standard and token. Standard coin was full-bodied money. Its face value and intrinsic value (the pure gold content at market price) were the same. It was the unit of account, unlimited legal tender and a standard for deferred payments. Minting was free only for standard coins. Token coins were multiples of standard coin and their face value was more than their intrinsic value. Token coins were legal tenders only up to a limit after which one could refuse to accept them in receiving

acquiring monopoly power in coin-making was its profit churning potential. The need to put a tab on money supply for curbing inflation and keep it commensurate with the overall needs of the economy was of smaller significance. Thus, money creation could not be left entirely to private discretion. And this brings us to the second major development.

The expanding international trade and the resultant complexity of foreign exchange issues added further to the growing governmental interest in the monetary affairs. Even as the authorities were attracted to money creation for a variety of reasons, especially the profit, it was sure to bring in, they did not consider it expedient to put their finger in the business directly; they chose to raise a facade – the Central Bank.

2.2.2 The rise of central banking

The process of government overtaking the creation of money proceeded on a slow pace. The first to come in were the regulations limiting the credit creation power of banks. They had to cope with some organizational restrictions including the continuation of the partners' liability as unlimited in banking far longer than in other businesses. But at the same time, the risks bankers took were sought to be reduced through severe penal provisions including in places even capital punishment for the defaulters.

The rise of democracy and the concern for human rights brought in some relief for the borrowers in the form of increased transparency in dealings and lowering of interest rates. Meanwhile, industrial revolution spread fast to other countries in Europe and their control of colonies had stabilized. International trade was rapidly expanding. The growth of wealth and prosperity of European nations became increasingly dependent on the colonies for obtaining industrial inputs and to sell finished products in their vast markets. Private banks still had the sway and there is an argument that their coalitions that had already started emerging in the face of liquidity shortages could presumably have efficiently functioned well also as 'the lenders of the last resort'. The argument candidly implied that the ushering in the central banks was not needed. (Gorton and Hung, 2001)

But the governmental objectives for intervention as stated above were different. Bank failures during the second half of the 19th century created the opportunity for intervention and a large number of banks collapsing

payments or discharge of debts. Token coins were made of base metals like copper and did not enjoy the facility of free coinage.

like a house of card during the inter-war period only helped hasten the process. Thus, central banks came into existence as a response to the inability of banks themselves to cope with panics (Goodhart, 1985). The process took the semblance of a natural evolution as some private banks were asked to operate as government's bank (Gorton & Hung, 2001).⁵ The authors provide some interesting information on the rising numbers of the central banks over time. This we reproduce in the following Table. Many of them were allowed to take up the 'Lender of the last resort' function much later.

Table 1: Growth of central banks over time

Year	1900	1950	1990
Number of central banks	20	59	161

3. Central banks and economic stability

The declared objective of establishing a central bank in a country was to have an institution devoted to keeping stable the value of its currency both internal and external. For performing the function, central banks were given some privileges: inter alia they were to serve as bankers to the government, granted the sole right for issuing currency notes, adopt measures to control the creation of credit by commercial banks and operate as the lender of the last resort. Central banks could not compete with ordinary commercial banks for business in the market. They had to guide and help the latter with a view to achieving stability in the value of money. Since coins of gold were already in circulation in many countries, central banks were to streamline the system for the issuance of currency with reference to the yellow metal. The rules for such streamlining were embodied in what came to be known as gold standard described below.

⁵ Prior to the establishment of the Reserve Bank of India, the Imperial bank was entrusted to work for the government. Later it was converted into the State Bank of India and then nationalized. Even today in some matters it works as an agent of the RBI where the latter has no branches of its own. The State Bank of Pakistan is an off shoot of the same development.

3.1 The Gold standard

As explained earlier, paper money grew gradually out of gold coinage. The era of 100% reserve for note issue was very short. As a first step, a certain portion of (legal) money was allowed to consist of currency notes convertible into gold which could circulate along with coins. A one-on-one reserve of gold for paper currency was not needed to ensure convertibility as all people were rarely expected to seek conversion of their notes at the same time. Schemes of keeping gold reserves to cushion currency note issue varied among countries⁶. But the common element of them all was to have and maintain an overall relationship between the gold held in reserves and the volume of currency in the country. In other words, gold controlled the volume of money in circulation through keeping a minimum gold reserve, however defined. To invoke public confidence, monetary authorities had to keep the price of gold stable in the country. This was the essence of what was named in the literature as the *domestic gold standard*.

But gold standard as described above could not ensure price stability at home. For, gold standard does not stabilize price levels; it merely stabilizes the relation between the volume of gold and the volume of currency. Even if the price of gold remains unchanged, fluctuations in the *volume* of gold must make the *volume* of currency vary, forcing variations in the general level of prices. Thus, Instead of stabilizing, the domestic gold standard forced prices to fluctuate⁷; it failed to curb inflation or to prevent depression.

Domestic gold standard was part of the evolution of money - not the result of 'invention' - and its extension to external transactions was part of the same process. When gold coins constituted most of the money supply in two countries, there was little room for variations in their exchange rate. So long as the two currencies A and B were freely convertible into gold at a fixed price, their rate of exchange could not vary from their *mint parity* by more than the small margin from what were called as the *gold points*. Any demand for foreign currencies that could not be met in the foreign exchange market at a rate within say 0.5 percent on either side of the *mint par* was shunted out to the gold market. Thus, the demand for any currency in the foreign exchange market always equaled its supply. The

⁶ For a brief discussion of these schemes, see Crowther (1948, pp. 281-300)

⁷ A reduction in the volume of *currency* may cause a reduction in the quantity of money or it may not the two can, on occasions, run divergent courses. See Crowther (1948, p. 297 where he also mentions a few historical examples of such diversions with reasons).

gap was covered by the gold movement across the two countries. Figure 1 explains the automatic nature of the balancing mechanism.

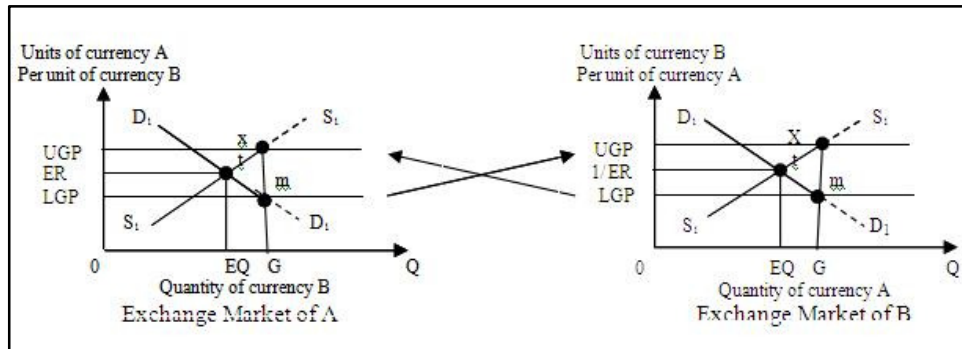

Figure 1: The Gold Standard Mechanism

It is assumed that currency A contains 3.2727273 grains of gold 11/12 fine while currency B has 10 grains of gold 9/10 fine. The *mint par* (the domestic price of foreign currency (ER) of the two currencies will then be:

$$\text{For country B: } \frac{10 \times \frac{9}{10}}{3.2727273 \frac{11}{12}} = 3 \text{ units of A per unit}$$

$$\text{For country A: Reciprocal of 3 i.e.} = 0.333333 \text{ of B per unit}$$

Assume further that the cost of transporting gold worth 1 units of currency A between the two countries is 0.0005 units of that currency. Then, in the foreign exchange market of country A the exchange rate $.3333 + 0.0005 = .3338$ will be the upper gold point (UGP), and the lower gold point (LGP) will be $(.3333 - 0.0005) = .3328$. We now have the apparatus to explain how gold standard would operate between the two countries.

If the demand for currency B starts rising relative to its supply in country A – the balance of payments moves against A – the exchange

rate in the market will start rising⁸ but it cannot cross the UGP⁹ as it will become cheaper for importers to buy gold in the market and export it to country B. D_1 will cease shifting up any more; excess of demand will move out from the currency market to that of gold, allowing only a tiny (tx) departure from ER. In contrast, if the balance of payments becomes increasingly favorable to country A, raising the supply of B currency relative to its demand in the exchange market, the ER will start falling: currency A will become dearer in country B. But the process cannot go on unabated. As soon as the rate crosses the upper gold point which would be the same as LGP in A -- again a small divergence (tm) from ER - the importers in country B will find it cheaper to ship gold to country A rather than buy currency in the exchange market. Under gold standard no country can stop either export of gold or its import. Gold standard works on the assumption that at gold points the supply of the metal is kept perfectly elastic. The assumption could become a reality only if countries or some international authority is willing to buy and sell at a fixed price.

Stability of exchange rates is desirable, rather necessary, in the present era of globalization for promoting free trade and liberalization, but on a *return to gold* only the naïve or the vested interests will insist. Let me explain very briefly the reasons as to why the return is neither desirable nor practicable. The issue of internal stability, I have already touched upon. Under the strict rules of the game, it is realistic to assume that the central bank of country A keeps gold in reserve just what is obligatory, say 40% of notes in circulation, to ensure their convertibility. Suppose now that there is an inflow of gold, ignoring reasons, worth \$ 1 million. This moves into the reserves of the central bank. If it does not, as it cannot, build a buffer stock of gold, it must put additional notes worth \$ 2.5 million in circulation. And if the banking system is to maintain a 10% reserve for credit creation the economy would become awash with a monetary expansion of \$ 25 million. This multiple expansion of money supply may impose inflationary pressures on an otherwise stable economy. You may work out the deflationary potential of gold out flow of a similar magnitude. In fact, gold standard inherently carries a deflationary bias: a country losing gold must contract credit but the one receiving it is under no compulsion to expand credit.

⁸ For a real world illustration see Halm (1956, pp.176-177). He explains how the exchange rate between USD and Pound Sterling was settled when both countries were on gold standard during the inter-war period

⁹ It may be noted, as shown in Figure 2, that the gold export point of one country becomes the gold import point of the other country and vice versa.

Gold standard can work smoothly if prices - wages in particular - were reasonably flexible, there were no structural rigidities in the economy, and public authorities were willing to surrender their discretion and independence to the automation requirements of gold standard mechanism. The suspension of gold standard under adverse circumstances in the past was the proof of the unwillingness of policy makers to accept such surrender.¹⁰ This unwillingness has only become more obstinate with the passage of time. This obstinacy was one of the reasons why the original designers of the IMF scheme rejected a return to gold standard so as to impart a measure of flexibility in the arrangement; the amendments of 1978 buried the gold-link for good.

Until the beginning of the last century, the measure of money requirements was the amount of the work money had to do, largely as a medium of exchange. Given the velocity V of money circulation, the measure was in close harmony with the level of real output. Even as per this criterion, the quantity of money needed could initially be managed; but gold supplies soon fell short to meet the monetary needs of economic expansion and currency notes with partial metal backing soon appeared on the scene to supplement coins. Compare this situation with the current scenario.

During the second half of the last century the real output the world produced was more than what it could during its entire existence before 1950. Where is the gold to support money expansion to match the increase? The growing volume of financial transactions knows no bounds. More than a trillion US\$ go round the world stock markets every twenty four hours in speculative trading. It is estimated that the volume of money involved in foreign exchange spot transaction alone is 70 times of the money value of world's real output. Supply of money tied to gold would fail to meet the money requirements of the modern age. One may be fond of day dreaming but return to gold is not even worth that dream. Today, financial transactions are an ocean wherein real transactions are just a tiny island. Return to gold (Dinar) is not possible (Hasan, 2008).

Since the last semblance of national currencies being linked together via gold disappeared forty years back, all countries have been running their economies entirely with fiat money; the money which is not backed by the reserve of any real commodity. Legal tender laws are the legs on

¹⁰ For a detailed explanation of the monetary expansion and contraction processes under the gold standard and their repercussions, see Halm (1956, Chapter 12, section 4 pp. 189-192).

which it stands. To me it is true money. It is not the moon drawing its shine from the sun – the reserves. It is the sun itself.¹¹

3.2 Creation of money

Undergraduate text books on money and banking invariably make a distinction between legal tender money as issued by the central bank of a country and credit or bank money that is generated by commercial banks through the granting of loans to borrowers. They also teach us that fiscal policy of a country falls in the government terrain while the monetary policy is autonomously designed and operated by its central bank. All such lessons must be taken with a grain of salt.

The early central banks were established when the mercantilist era was still on. They were brought into existence by powerful businessmen controlling politics for serving their own nefarious ends (DeLorenzo, 2008). Ownership structures and the role of central banks have since witnessed many changes over time and space but their basic functions have virtually remained unaltered (Goodhart, 2010)¹². Three of their functions – (i) working as bankers to the government, (ii) being the sole issuer of currency notes and (iii) controlling of credit the commercial banks create – unfold the linkage between the fiscal and monetary policies of a country and the extent of a central bank's autonomy.

3.2.1 Fiscal policy- money supply interface

The function of the central bank to work as the banker to the government opens the window for the latter to interfere with the supply of currency or *base money* in the country. Even as the central banks have the sole right to issue currency notes, the right has not always been absolute. For example, in India, the one rupee note which is unlimited legal tender was issued by the government of India not by the RBI. The government could always

¹¹ It will be wrong to believe that we have fiat money for the first time now. In fact, even during the era of commodity money there were legal tender laws put in operation to strengthen the monetary systems. These laws legally relieved the debtors of their obligations if they offered to pay the debt using what government declared as money. In some cases refusal to accept this form of payment was illegal and could at times attract even death penalty. Ancient Rome and post-revolution France are cited as examples. (Cobb 2010. Why Cobb (p.12) calls it a major breakthrough in the history of money is not clear. In the past the existence of fiat money was an exception, today its non-existence is an exception.

¹² However, there is a strong case for scrutinizing the power structure in the central banks, especially the ones operating in the area of Islamic banking. This can bring to light forces influencing their workings.

exchange these notes for bigger denomination with the latter. The second source is that the government can always borrow currency from the RBI through the creation of treasury bills which the latter could sell in the money market. The conversion of government securities into legal tender money at the RBI was used by the British to unleash unprecedented inflationary pressures on the Indian economy to their own advantage.¹³

Table 2: Exchange rates: 1US\$ value in German Mark

Jan. 1918	5.21	Mar. 1923	21,190.00
Jan. 1919	8.20	Apr. 1923	24,475.00
Jan. 1920	64.80	May 1923	47,670.00
Jan. 1921	64.91	June 1923	109,966.00
Jan. 1922	191.81	July 1923	353,412.00
April 1922	291.00	Aug. 1923	4,620,455.00
July 1922	493.22	Sept. 1923	98,860,000.00
Oct. 1922	3,180.96	Oct. 1923	25,260,000,000.00
Jan. 1923	17,972.00	Nov. 1923	2,193,600,000,000.00
Feb. 1923	27,918.00	Dec. 1923	4,200,000,000,000.00

Source: Schools History –The seeds of evil: The rise of Hitler

(ASK.Com// Downloaded on 10.01.2011)

¹³ In short the story was as follows. When England returned to Gold Standard after the WW1 in the twenties, the Indian rupee was tied to it at a fixed rate to have the *prestige* of being on gold (exchange) standard via the Sterling. In 1931 England went off the Gold Standard but the Indian rupee remained hanging by the Sterling coat minus the prestige. The linkage enabled the British to finance their huge balance of payments deficits with the country during the WW2 period through making RBI issue Indian currency against the piling up sterling debt, paper just replacing paper. Real goods and services moving to War Theater and money supply expanding within led to high inflation in India. It is interesting to note that inflation rate in England at war averaged not more than 7% a year during 1940-1945. Domestic inflation was largely transferred to India (and other colonies).

Another example, an eye-opener, comes from the German economy during the 1920s. After their victory in the WW1 the allied powers imposed such heavy reparation on the vanquished that the payments devastated the economy of the country as never before in modern history. The annual national income plus the liquidation of the accumulated wealth of the Germans was not sufficient to maintain the payments schedule. On the one side of the road the central bank was printing notes day and night so that the government could purchase goods from the market for export to meet the dates. On the other side the Germans ran with basketfuls of currency to beat the spiraling inflation – in one year prices rose 10^{13} times. Inflation ran parallel to the depreciation of the German Mark that in fact had caused it. Table 2 (given above) presents the depreciation drama.

Figure 2

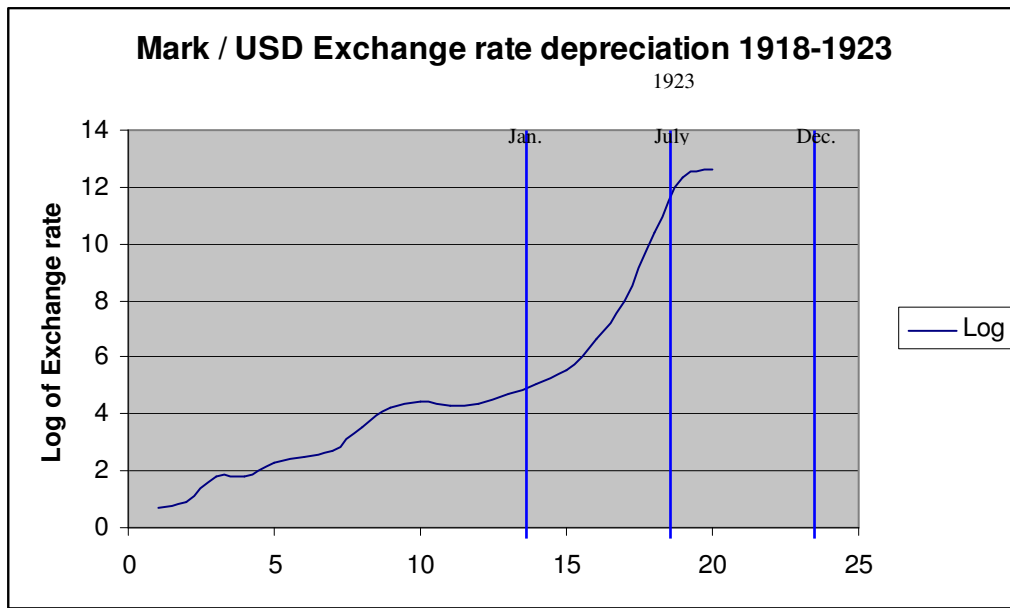

Figure 2 is constructed using Table 2 data on semi-logarithmic scale to keep its size manageable. We did not put the actual dates on X-axis to avoid congestion.

In Pakistan also the central bank of the country is at a loss to find ways of liquidating the huge debt the government owes to it as the consequence of deficit oriented fiscal policies of successive governments. The bank had to print notes unmatched with the corresponding expansion in real output. The result was continual depreciation of the currency in the foreign exchange markets and inflation at home.

It follows from the above discussion that the central bank cannot determine the monetary base exogenously. It erodes the capability of the central bank to discipline the banking system and tempts the banks to defy cautions in credit creation that brings their owners large effortless leverage gains. This requires us to understand the credit creation power of banks and its limits.

3.2.2 Money creation by banks

We have already made a distinction between (i) currency or legal tender money and (ii) the bank credit or bank money. The two together constitute the M_1 version of money supply. The relationship between them lies at the heart of credit creation process that commercial banks follow. The volume of (i) i.e. currency in an economy serves as the *base* for generating (ii) the credit money. Part of the base money (currency) always remains *inside* the central bank while the remaining part is held *outside* by the public¹⁴. People deposit a part of the *outside* money with them in commercial banks as demand or time deposits which together constitute the *cash* deposits of the bank. A portion of deposits, say 10%, the banks have to keep with them as statutory reserve to meet the daily withdrawal needs of the depositors; the remaining they can lend on interest or invest in the Islamic profit earning schemes. In conventional banks the sum loaned is credited to the account of the borrower. Thus, loans generate what we call *credit* deposits. These loans and deposits appear one for each other as contra entry in the bank balance sheets. The banks make no distinction between the two sorts of deposits – cash or credit – in their lending operations.

To illustrate, let us assume that the amount of currency or base money circulating in a country at a time point is 100T half of which people keep with them under the Keynesian liquidity preference motives; the remaining 50T they deposit with the commercial banks. Suppose the banks on an average retain F fraction of their cash deposits as reserve to meet the daily withdrawals while the central bank wants them to maintain with it a minimum fraction R of their deposit – cash plus credit. How much credit can a bank create with these constraints? The credit multiplier M provides the answer. It is calculated as under.

$$M = 1/F [1 - R]$$

¹⁴ The classification of currency into outside and inside money is of recent origin and some economists have found it a useful explanatory tool in their discussion of the credit creation process of commercial banks.

Suppose a bank has 50M in cash deposits and has to keep $F = 0.1$ fraction of the sum every moment in its safe to meet the daily withdrawal demands. Furthermore, the central bank requires each commercial bank to maintain with it 5% of its deposits – cash plus credit - in the form of cash implying $R = 0.05$. The credit multiplier M will then be 9.5. The 50M cash deposit with the bank will enable it to have total deposits worth $50 \times 9.5 = 475M$. From that amount if we take out cash deposits, the remaining 425M will be the *credit* (loan) deposits the bank has generated. Note that an individual bank cannot create credit disproportionate to others because on balance it will soon find its cash flows reducing via inter-bank clearances. The cash string forces it to remain with the group. However, the created creation power of the banking system is on the whole tremendous. The interest received on this amount minus the part of it payable for cash deposit holders and other operating expenses will all belong to the bank. Banking is thus an exceedingly lucrative business. Collectively, banks may generate a huge inverted pyramid of credit.

Businesses too are tempted to support the process as the rates of interest are usually much lower than returns the borrowings provide. Producers are tempted to finance even long run projects from short-term borrowings because in good times repeated and easy renewals can convert them into long-term funding. Leverage gains tend to make businesses over adventurous. But continued pumping in of funds ultimately causes the credit balloon burst, economies roll down the hill and unemployment tends to become rampant. Should Islamic banks indulge in credit creation as do the commercial banks as a part of the process? I refrain from discussing this issue here because I have already discussed it threadbare in my earlier writings (Hasan, 2008 and 2010) However, put briefly my position is as follows.

3.2.3 Islamic banks: credit creation and the crisis

Commercial banks and their functions evolved over time in response to the changing and expanding needs of trade, industry and commerce. Eventually, they emerged for meeting the short-term needs of business. These needs have been of seasonal character and creation of base money was geared to the more enduring demand for money to serve as a medium of exchange and a store of value. Credit creation is meant to keep the growth of base money smooth over time. This development left untouched the financing modes in Muslim lands. Islamic finance emerged on the scene very late for a variety of reasons. Innocuously, it chose to follow in the footsteps of the same system that it rose to replace. To me, Islamic banks have little option in the matter of credit creation: their methods and

precautions could of course be different. The real problem in fact is on the control side: what would or could replace the bank rate as control weapon in the hands of the central bank. Even in the case of conventional banks, the policy has failed to deliver. Long run profit expectations tend to run much higher above the schedules of interest rates after the WW2. The rising leverage ratios and commissions have to be curbed. Perhaps, there exists a case for taxation of leverage gains with steep progression.

It seems a bit misguiding to claim that Islamic banks withstood the current crisis better than their mainstream counterparts. They are yet too small to catch the cold and have not nursed the linkages for infection. And yet many Islamic banks did come to grief. Kuwait has recently refused to bailout the defaulting banks in the country.

4. Concluding remarks

This paper had set out to discuss some familiar ideas in the area of money creation and control in modern societies from an Islamic angle but arrived at some unfamiliar conclusion. The main ones are as under:

- i) Money evolved as a social convention. Its essence lies in what it does, not in what it is made of. Its significance follows from the fact that it tears apart the two sides of the barter coin into sale and purchase. Money has no religious content. It was never nor can ever be divided into Islamic and non-Islamic
- ii) Gold standard was evolved by the erstwhile imperial powers to exploit colonies for obtaining raw material and other inputs for their growing industries and open their vast markets for selling their products. It sacrificed the internal stability at the cost of external stability. That often hurt the developing nations, Gold standard never ensured that none will lurch; it only ensured that all will lurch together. The world should never return to gold. Presently, the IMF rules bar the linking of any currency to gold. The *dinarists* are traveling on a blocked end road.
- iii) The autonomy of central banks is illusory. Governments have always been the prime movers in the matter of money supply. Fiscal policies have frequently been the undoing of monetary policies initiated by central banks. Governors of central banks are after all appointed by the government; they have to watch the movement of the authoritative eyes. They tend to be late to miss the train and under kill to avoid the charge of over killing.

I believe that any system can possibly deliver if human element is virtuous. Human beings are the greatest source of instability in the world – political, economic and social. Presidents retire and only then the nation knows that they bankrupted the nation for self-enrichments. Corruption, conspiracy and injustice rule the world. Powerful armies have marched for non-existent reasons into flourishing countries and destroyed them completely and for that they got away by merely saying sorry. The entire nations as Greece have gone bankrupt because of the misdeeds of their rulers – democratic or despotic. Today, if banks are too big to fail, nations are much bigger. To me all reforms will fail to deliver unless human beings are reformed. Rational morality has failed; faith is the hope.

4.1 Acknowledgements

I express my gratitude to Datuk Agil Nutt the CEO of INCEIF who spares time to go through the initial drafts on my papers and readily comes back with his insightful and constructive comments. I am also thankful to my students Mughees Shoukat and Nurhafiza Abdul Kader Malim at INCEIF who helped me as usual with data collection and proof readings of the earlier drafts of the paper. The usual disclaimer applies.

Bibliography

1. Cizakca, Murat, (2010): *The case against the Islamic gold dinar*, MPRA Paper 26645, University Library of Munich, Germany.
2. Cobb, Steven (2010): *The history and evolution of money*, UNT Center for Economic Education, Downloaded from (www.wikipedia.org/wiki/History_of_Money), downloaded on January 7, 2011.
3. Collyns, Charles (2008): *The crisis through the lens of history*, Finance and Development (December).
4. Crowther, G. (Second edition 1948): *An outline of money*, Thomas Nelson & Sons, London (Chapter IX, pp.277-335).
5. DiLorenzo, Thomas J. (November 2008): *The corrupt origin of Central Banking*, Mises daily, Ludwig Von Mises Institute, Austria.
6. El-Gamal Mahmoud (2010): *Incoherence of contract based Islamic financial jurisprudence in the age of financial engineering*, A Rice University Mimeo.
7. Fisher, Omar (2009): *An Islamic view of the credit crisis*, IBF 409 Issue: 41
8. Gide, C & Rist, C (1953): *History of economic doctrines*,: George, Harrap and co. New Delhi
9. Goodhart, C. A. E (November (2010): *The challenging role of central banks*, BIS Working paper No. 326, Monetary and Economic Department, Bank for International Settlements.
10. Gorton, Gary & Huang, Lixin (2001): *Banking panics and the origin of central banking*; Working paper, The Wharton School, University of Pennsylvania and NBER.
11. gtnews.com (16 December 2008): *Commentary – The credit crisis timeline*. (www.gtnews.com) pp.1-10.
12. Halm, George N. (1965 print): *Monetary theory: A modern treatment of the essentials of money and banking*, Asia Publishing House, Bombay, (Chapter 12, pp.171-209).
13. Hasan Zubair (2010): *Profit sharing ratios in mudaraba contract*, International Journal of Banking and Finance, The Berkley Electronic Press.

14. Hasan, Zubair (2008): *Credit creation and control: An unresolved issue in Islamic banking*, International Journal of Islamic and Middle Eastern Finance and Management, Vol. 1, No.1 pp 69 – 81).
15. Hasan, Zubair (2009): *Ensuring exchange rate stability: Is return to gold (Dinar) possible?*.KAU Journal of Islamic Economics; Vol.21, No.2
16. IMF Staff Position Note, (October 2010): *Shaping the new financial system*, Monetary and Capital Markets Department.
17. Kazmi, Mubashir Zein (October 2010): *Islamic Dinar reloaded*, Opalesque: Islamic finance Intelligence issue 12 -03).
18. KFH Research (2011): *Gold Dinar: Time to return?* Monograph pp.1-21 Kuwait Finance House Research Ltd.
19. Laurent Well (2010): *Do Islamic banks have greater market power*, BOFIT: Working Paper 548, Economic Research Forum.
20. Nienhause, Volker (2010): *Islamic finance and financial crisis*, Islamic Financial Services Board, Kuala Lumpur, Malaysia.
21. Tlemsani, Issam and Mathews, Robin (Undated): *Ethical banking: Islamic house financing in the United Kingdom – A comparative study*, (Unpublished)
22. Wemer, Richard A (2010): *Understanding and forecasting the credit cycle- why the mainstream paradigm in economics and finance collapsed*. QFINANCE, Download 1/6/2011
23. Zein, Mubasher, Zein (2010): *Islamic Islamic Dinar Revisited*, Opalesque, Islamic Faineance Intelligence Issue 14-15 INCEIF Digital Library.
24. Zeollick, Bob (2010): *On monetary reforms*, Bullfax.com – Market News and analysis, www.bullfax.com downloaded 12;28, 2010